

NES-A-CK (USA-2)

# NES CLEANING KIT™



Nintendo of America Inc.  
P.O. Box 957, Redmond, WA 98073-0957 U.S.A.

PRINTED IN JAPAN

INSTRUCTION MANUAL

*This official seal is your assurance that Nintendo has reviewed this product and that it has met our standards for excellence in workmanship, reliability and entertainment value. Always look for this quality seal when buying games and accessories to ensure complete compatibility with your Nintendo Entertainment System.*



Thank you for purchasing the NES Cleaning Kit™. By regularly using this cleaning kit, you will extend the life of your Nintendo Entertainment System® Control Deck™ and Game Paks.

### **IMPORTANT**

Please read the instructions carefully before using your cleaner. Failure to read and follow these instructions may result in damage to your Control Deck™. If, after reading these instructions, you have any questions about use of the NES Cleaning Kit™, please call our Consumer Service Department at the number below:

### **NEED HELP?**

Nintendo Consumer Service Hotline  
**1-800-255-3700**

Mon.-Sat., 4:00 a.m.-12:00 Midnight

Sun., 8:00 a.m.-5:00 p.m., All times are Pacific time.

Hours of operation are subject to change without notice.

## A. CLEANING GAME PAKS

- ▶ Game Paks should be cleaned at least once a month or whenever they become dirty.
1. Remove the cleaning wand from the plastic bag.
  2. With your finger, apply a small amount of water\* to the blue end of the cleaner until it is slightly damp.  
\* If possible, distilled water should be used. OR  
For maximum cleaning effect, use a mixture of 1 teaspoon isopropyl alcohol and 1 teaspoon water.
  3. Rub *both sides* of the Game Pak edge connector by pressing against it gently with the blue end of the cleaner. Move the cleaner side to side to clean all of the edge connector pins. (See Drawing A.)
  4. With the white end of the cleaner, gently dry both sides of the Game Pak edge connector.
  5. Check the connector pins on both sides of the Game Pak. They should be clean and have a shiny gold finish. If not, repeat steps 3 and 4.

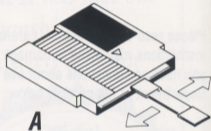

## B. CLEANING THE CONTROL DECK

- ▶ The Control Deck should be cleaned at least once a month or whenever dirty. Clean the Control Deck at the same time you clean your Game Paks for best results.

**WARNING — NEVER CLEAN YOUR CONTROL DECK WHILE IT IS PLUGGED IN!**

1. Unplug the power cord from the Control Deck at either the wall outlet (transformer) or the back of the Control Deck.
2. Open the NES cleaning cartridge by gently pressing on the tab on the side and lifting off the lid. Remove the flat Control Deck cleaning card. (See Drawing B.)

## CLEANING CARD

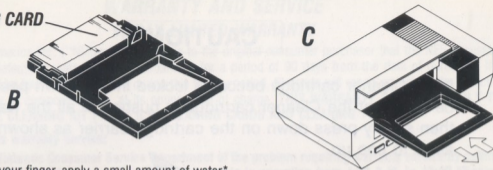

3. Using your finger, apply a small amount of water\* to both sides of one of the long edges of the card until it is slightly damp.  
\* If possible, distilled water should be used. OR  
For maximum cleaning effect, use a mixture of 1 teaspoon isopropyl alcohol and 1 teaspoon water.
4. Reassemble the cleaning cartridge with the damp edge of the card facing out. Insert the cleaner into the Control Deck as you would a Game Pak. Push the cleaner into the down position and move the cleaner in and out 5-10 times. (During the cleaning process, the cleaner will move forward and backward about  $\frac{3}{4}$ ".) (See Drawing C.)
5. Remove the cleaning cartridge and allow the Control Deck to dry for at least 1 hour before plugging it back in and turning it on.

## Additional Hints

- ▶ After cleaning your Game Paks and Control Deck many times, the cleaning surfaces may become dirty. Replace the dirty parts with the replacement parts provided or wash them with liquid dish soap. Rinse the parts very thoroughly and allow to dry.
- ▶ Additional Cleaning Kit parts can be ordered from Nintendo by using the following order form or by calling Nintendo Consumer Service at 1-800-255-3700.
- ▶ The cleaning wand and two extra cleaning tips can be stored in the extra compartments found inside the cleaning cartridge.

## CAUTION

If the Cleaner cartridge becomes locked in the Down position, be sure that the Cleaner cartridge is pushed in all the way and then simply press down on the cartridge carrier as shown, and allow to pop up.

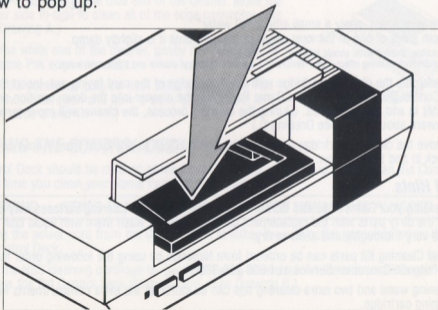

## WARRANTY AND SERVICE

### 90-DAY LIMITED WARRANTY

Nintendo of America Inc. ("Nintendo") warrants to the original consumer purchaser that the NES accessory shall be free defects in material and workmanship for a period of 90 days from the date of purchase. If a defect covered by this warranty occurs during this 90-day period, Nintendo will repair or replace the defective NES accessory or component part, at its option, free of charge. **THIS WARRANTY DOES NOT APPLY TO REPLACEABLE CLEANING KIT PARTS (I.E. CLEANING CARDS AND CLEANING TIPS).**

To receive this warranty service:

- 1) Notify the Nintendo Consumer Service Department of the problem requiring warranty service by calling: 1-800-255-3700. Our Consumer Service Department is in operation from 4:00 A.M. to 12:00 Midnight Monday through Saturday and 8:00 A.M. to 5:00 P.M. on Sunday. (All times are Pacific time. Hours of operation are subject to change without notice.) Please do not send your defective components to Nintendo before calling the Nintendo Consumer Service Department.
- 2) If the Nintendo service representative is unable to solve the problem by phone, the representative will provide you with a Return Authorization number. You must record this number on the outside packaging of your defective NES accessory (do not send in original box) and return your NES accessory **FREIGHT PREPAID AND INSURED FOR LOSS OR DAMAGE**, within the 90-day warranty period, to:

Nintendo of America Inc.  
NES Consumer Service Department  
4820 150th Avenue N.E.  
Redmond, WA 98052  
RA # \_\_\_\_\_

The consumer service representative may alternately refer you to a Nintendo World Class Service Center<sup>SM</sup> in your area. (You do not need a Return Authorization number for service.)

This warranty shall not apply if the NES accessory has been damaged by negligence, accident, unreasonable use, commercial use, modification, tampering, or other causes unrelated to defective materials or workmanship, or if the serial number has been removed or defaced.

### REPAIRS AFTER EXPIRATION WARRANTY

If the NES accessory develops a problem requiring service after the 90-day warranty period, you may contact the Nintendo Consumer Service Department at 1-800-255-3700 (4:00 A.M. to 12:00 Midnight Monday through Saturday and 8:00 A.M. to 5:00 P.M. on Sunday. All times are Pacific time. Hours of operation are subject to change without notice.) If the Nintendo service representative is unable to solve the problem by phone, the representative may advise you of the approximate cost for Nintendo to repair or replace the NES accessory and a Return Authorization number will be given to you.

You must then record this number on the outside packaging of the defective NES accessory and return the defective merchandise, **FREIGHT PREPAID AND INSURED FOR LOSS OR DAMAGE**, to Nintendo, and enclose a money order or personal check payable to Nintendo of America Inc., for the cost quoted you. (Repairs may also be charged on a VISA or MASTERCARD credit card.)

The consumer service representative may alternately refer you to a Nintendo World Class Service Center<sup>SM</sup> in your area. (You do not need a Return Authorization number for service.)

If after personal inspection, the Nintendo service representative determines the NES accessory cannot be repaired, it will be returned and your payment refunded.

### WARRANTIES LIMITATIONS

ANY APPLICABLE IMPLIED WARRANTIES, INCLUDING WARRANTIES OF MERCHANTABILITY AND FITNESS FOR A PARTICULAR PURPOSE, ARE HEREBY LIMITED TO NINETY DAYS FROM THE DATE OF PURCHASE AND ARE SUBJECT TO THE CONDITIONS SET FORTH HEREIN. IN NO EVENT SHALL NINTENDO BE LIABLE FOR CONSEQUENTIAL OR INCIDENTAL DAMAGES RESULTING FROM THE BREACH OF ANY EXPRESS OR IMPLIED WARRANTIES.

The provisions of this warranty are valid in the United States only. Some states do not allow limitations on how long an implied warranty lasts or exclusion of consequential or incidental damages, so the above limitation or exclusion may not apply to you. This warranty gives you specific legal rights and you may also have other rights which vary from state to state.

### NES CLEANING KIT CONSUMER PARTS LIST & ORDER FORM

Nintendo Part No.	Part Name	Price	Qty.	Amount of Purchase
18528	REPLACEMENT CLEANING KIT PARTS (Includes 4 cleaning cards and 4 cleaning tips)	\$8.00		
SUBTOTAL				
WASHINGTON STATE RESIDENTS ADD 8.1% SALES TAX				
POSTAGE & HANDLING (\$2 for order of \$4 or more, \$0.50 for orders of less than \$4)				
99004 • FOR EXPEDITED SHIPPING SERVICE (2 DAY AIR FREIGHT) PLEASE ADD AN ADDITIONAL \$2.50.				
TOTAL AMOUNT DUE				

**To Order by Phone (Requires VISA or MASTERCARD)** Call: 1-800-255-3700, 4:00 A.M. to 12:00 Midnight Monday through Saturday and 8:00 A.M. to 5:00 P.M. on Sunday. (All times are Pacific time. Hours of operation are subject to change without notice.) Please have your VISA or MASTERCARD card number and expiration date ready.

#### To Order by Mail, Please Complete the Following:

- Name \_\_\_\_\_ Phone ( ) \_\_\_\_\_  
Street Address \_\_\_\_\_  
City \_\_\_\_\_ State \_\_\_\_\_ Zip \_\_\_\_\_
- Enclose Money Order or Credit Card Authorization for Total Amount Due.  
If paying by VISA or MASTERCARD:  
Please charge total amount due of \$ \_\_\_\_\_ to my:  VISA  MASTERCARD  
CARD # \_\_\_\_\_ Expiration Date \_\_\_\_\_  
Name on Card (Print) \_\_\_\_\_  
Signed \_\_\_\_\_
- Mail to: **Nintendo of America Inc., P.O. Box 97032, Redmond, WA 98073-9732**

Allow 6-8 weeks for delivery. We cannot accept cash or C.O.D. orders. Prices are applicable within the United States only and are subject to change without notice.

**YES CLEANING KIT CONSUMER PARTS LIST & ORDER FORM**

Part No.	Part Name	QTY	Notes
101	Kit Case	1	
102	Kit Contents	1	
103	Kit Instructions	1	
104	Kit Manual	1	
105	Kit Accessory	1	

Kit includes everything you need to get started. The kit contains a cleaning solution, a spray bottle, and a microfiber cloth. The kit is designed to be used on a variety of surfaces including glass, stainless steel, and chrome. The kit is also suitable for use on other surfaces such as plastic, wood, and fabric. The kit is a great value for the money and is a must-have for anyone who wants to keep their home clean and shiny.

To Order by Phone: Please call 1-800-555-1234. To Order by Mail, Please Complete the Following:

Name \_\_\_\_\_  
 Street Address \_\_\_\_\_  
 City \_\_\_\_\_ State \_\_\_\_\_ Zip \_\_\_\_\_  
 Phone (\_\_\_\_) \_\_\_\_\_

Kit includes everything you need to get started. The kit contains a cleaning solution, a spray bottle, and a microfiber cloth. The kit is designed to be used on a variety of surfaces including glass, stainless steel, and chrome. The kit is also suitable for use on other surfaces such as plastic, wood, and fabric. The kit is a great value for the money and is a must-have for anyone who wants to keep their home clean and shiny.

Kit includes everything you need to get started. The kit contains a cleaning solution, a spray bottle, and a microfiber cloth. The kit is designed to be used on a variety of surfaces including glass, stainless steel, and chrome. The kit is also suitable for use on other surfaces such as plastic, wood, and fabric. The kit is a great value for the money and is a must-have for anyone who wants to keep their home clean and shiny.